

Rooftop/Plant Room Energy or Heat Recovery Ventilator 250-8000 l/s



The Rooftop/Plant Room Energy and Heat Recovery Ventilator range is designed to be used when high fresh air quantities are required. They can be retrofitted into existing air conditioning systems to improve indoor air quality, whilst still maintaining system efficiency.

Energy Efficient Construction

- Cabinets are constructed of 50mm BHP Colorbond Coolroom panel, for best practice insulation.
- Purpose built UV treated polymer joiners are used to eliminate heat loss through the body of the unit.
- The heat exchanger incorporated into the unit reclaims up to 75% of the sensible and latent energy (ERV) from the exhaust stale air, therefore saving up to 75% of the cost to heat or cool outdoor air.
- Also available with sensible heat exchanger to reclaim up to 80% of temperature only (HRV).
- Air Change units are designed with extremely large access doors to ensure that all parts are easily accessible for servicing and replacement.

Features

- Fans incorporating three phase fan motors (2000 l/s and over) are direct coupled, therefore eliminating the need for pulleys and belts.
- Supply and exhaust air three phase fan motors are controlled with separate VSD controllers with benefits including;
 - i. Ramped starting of fan motors, leading to a prolonged life of all fan and motor components and eliminate starting power / amperage spikes.
 - ii. Dramatically reduced commissioning times as airflow is adjusted simply by a control knob and no need for pulley / belt adjustment.
 - iii. Easy integration to a BMS system.
 - iv. Saves running costs by precisely controlling power needed to the motor.



Rooftop/Plantroom ERV and HRV Options

RA Bypass

Used in high load or start-up conditions. Allows the unit to run with as low as 50% fresh air thus reducing the fresh air load of the system. Motorized damper optional.

Economy Cycle

Used in comfortable ambient conditions. Fresh air bypasses the heat exchanger and compressors switched off, saving energy.

Hot/Cold water coil

ERV/HRV units can incorporate hot or cold water coils to increase maximum capacity.

High Static Fan Upgrade

Fan upgrades available for high flow or high external static pressure drops.

Corrosion Resistant

Corrosion resistant packaging available for harsh environments.

CO₂ sensors

Used to vary fresh air levels to improve indoor air quality with minimum running cost according to CO₂ levels detected by sensors.

Contact Air Change for assistance with options



PLANT ROOM / ROOFTOP ENERGY RECOVERY VENTILATORS (ERV-RT)

Model No.	Installation Type	Air Flow	Overall Dimensions	Supply Air Spigot	Return Air Spigot	Approximate Weight	Nominal Running Amps (per phase)	Phase	Electrical Input
		L/s	H X D X W	H X W	H X W	kg	Amps		kW
ERV250-RT*	Plant room /Rooftop	150-250	895 x 1160 x 955	300 x 235	330 x 655	124	3.2	1	0.57
ERV550-RT*	Plant room /Rooftop	250-550	1040 x 1230 x 1255	300 x 695	330 x 955	163	7.9	1	1.40
ERV750-RT*	Plant room /Rooftop	550-750	1040 x 1230x 1255	300 x 695	330 x 955	183	8.0	1	1.41
ERV1000-RT*	Plant room /Rooftop	750-1000	1155 X 1260 X 1600	300 X 950	330 X 1300	222	10.6	1	1.87
ERV1500-RT*	Plant room /Rooftop	1000-1500	1295 X 1480 X 2200	300 X 1050	330 X 1900	332	17.6	1	3.00
ERV2000-RT*	Plant room /Rooftop	1500-2000	1295 X 1480 X2200	300 X 1050	330x1900	353	19.6	1	3.47
ERV2500-RT	Plant room /Rooftop	2000-2500	1770 X 1825 X 2250	380 X 870	620 X 1950	736	16.0	3	9.10
ERV3000-RT	Plant room /Rooftop	2500-3000	1770 X 1825 X 2250	380 X 870	620 X 1950	768	21.6	3	12.91
ERV3500-RT	Plant room /Rooftop	3000-3500	1770 X 1885 X 2900	425 X 1050	620 X 2600	963	21.6	3	12.91
ERV4000-RT	Plant room /Rooftop	3500-4000	1770 X 1885 X 2900	425 X 1050	620 X 2600	978	28.6	3	17.30
ERV4500-RT	Plant room /Rooftop	4000-4500	2040 X 2275 X 3550	500 X 1200	620 X 3250	1289	28.6	3	17.30
ERV5000-RT	Plant room /Rooftop	4500-5000	2040 X 2275 X 3550	500 x 1200	620 X 3250	1358	31.2	3	17.75
ERV6000-RT	Plant room /Rooftop	5000-6000	1820 x 2095 x 4200	380 x 2000	620 x 3900	1506	30.8	3	17.75
ERV7000-RT	Plant room /Rooftop	6000-7000	1820 x 2195x 4850	425 x 2400	620 x 4550	1744	43.2	3	29.39
ERV8000-RT	Plant room /Rooftop	7000-8000	1820 x 2195 x 5500	425 x 2400	620 x 5200	1946	57.2	3	34.33

*** For standard ERV-RT 250 up to 2000, the fans are direct drive 1 Phase, with VSD optional.**

Please contact Air Change Engineers for units larger than 8000L/s airflow duty



Energy Reclaimed by Heat Exchanger Cooling* (kW) – ERV (Latent and Sensible Transfer)

Airflow (L/s)	Sydney	Brisbane	North Queensland	Adelaide	Melbourne	Canberra	Darwin	Perth	Hobart
100	2.01	2.72	3.27	1.65	1.2	1.16	3.47	1.65	0.65
200	4.02	5.45	6.54	3.3	2.4	2.32	6.94	3.3	1.3
300	6.03	8.17	9.82	4.95	3.6	3.48	10.41	4.95	1.95
400	8.04	10.9	13.09	6.6	4.8	4.64	13.88	6.6	2.6
500	10.05	13.62	16.36	8.25	6	5.8	17.35	8.25	3.25
600	12.06	16.35	19.63	9.9	7.2	6.96	20.82	9.9	3.9
700	14.07	19.07	22.9	11.56	8.4	8.12	24.29	11.55	4.55
800	16.08	21.79	26.18	13.21	9.6	9.28	27.76	13.2	5.2
900	18.09	24.52	29.45	14.86	10.8	10.44	31.23	14.85	5.85
1000	20.1	27.2	32.72	16.5	12	11.6	34.7	16.5	6.5
1500	30.16	40.86	49.08	24.67	18	17.4	52.05	24.75	9.75
2000	40.2	54.5	65.4	33	24	23.2	69.4	33	13
2500	50.26	68.11	81.8	41.12	30	29	86.75	41.25	16.25
3000	60.3	81.7	98.2	49.5	36	34.8	104.1	49.5	19.5
3500	70.37	95.35	114.52	57.57	42	40.6	121.45	57.75	22.75
4000	80.4	109	130.9	66	48	46.4	138.8	66	26
4500	90.47	122.59	147.24	74.02	54	52.2	156.15	74.25	29.25
5000	100.5	136.2	163.6	82.5	60	58	173.5	82.5	32.5
6000	120.6	163.46	196.3	99	72	69.6	208.2	99	39
7000	140.7	190.7	229	115.6	84	81.2	242.9	115.5	45.5
8000	160.8	217.9	261.8	132.1	96	92.8	277.6	132	52

* Based on AIRAH design ambient conditions, 24°C/50RH% Indoor Conditions

Note that ventilators should be run in conjunction with conventional air conditioning to sustain indoor conditions



Energy Reclaimed by Heat Exchanger Heating* (kW) – ERV (Latent and Sensible Transfer)

Model No.	Sydney	Brisbane	North Queensland	Adelaide	Melbourne	Canberra	Darwin	Perth	Hobart
100	2.17	2.17	1.81	2.7	2.79	3.86	0.78	2.61	3.12
200	4.34	4.34	3.62	5.4	5.58	7.72	1.56	5.22	6.24
300	6.51	6.51	5.43	8.1	8.37	11.58	2.34	7.83	9.36
400	8.68	8.68	7.24	10.8	11.16	15.44	3.12	10.44	12.48
500	10.85	10.85	9.05	13.5	13.95	19.3	3.9	13.05	15.6
600	13.02	13.02	10.86	16.2	16.74	23.16	4.68	15.66	18.72
700	15.19	15.19	12.67	18.9	19.53	27.02	5.46	18.27	21.84
800	17.36	17.36	14.48	21.6	22.32	30.88	6.24	20.88	24.96
900	19.53	19.53	16.29	24.3	25.11	34.74	7.02	23.49	28.08
1000	21.7	21.7	18.1	27	27.9	38.6	7.8	26.1	31.2
1500	32.55	32.55	27.15	40.5	41.85	57.9	11.7	39.15	46.8
2000	43.4	43.4	36.2	54	55.8	77.2	15.6	52.2	62.4
2500	54.25	54.25	45.25	67.5	69.75	96.5	19.5	65.25	78
3000	65.1	65.1	54.3	81	83.7	115.8	23.4	78.3	93.6
3500	75.95	75.95	63.35	94.5	97.65	135.1	27.3	91.35	109.2
4000	86.8	86.8	72.4	108	111.6	154.4	31.2	104.4	124.8
4500	97.65	97.65	81.45	121.5	125.55	173.7	35.1	117.45	140.4
5000	108.5	108.5	90.5	135	139.5	193	39	130.5	156
6000	130.2	130.2	108.6	162	167.4	231.6	46.8	156.6	187.2
7000	151.9	151.9	126.7	189	195.3	270.2	54.6	182.7	218.4
8000	173.6	173.6	144.8	216	223.2	308.8	62.4	208.8	249.6

* Based on AIRAH design ambient conditions, 21°C/50RH% Indoor Conditions

Note that ventilators should be run in conjunction with conventional air conditioning to sustain indoor conditions



Energy Reclaimed by Heat Exchanger Cooling* (kW) - HRV (Sensible Only Transfer)

Model No.	Sydney	Brisbane	North Queensland	Adelaide	Melbourne	Canberra	Darwin	Perth	Hobart
100	1.06	0.88	0.97	1.45	1.24	1.1	0.97	1.45	0.65
200	2.12	1.76	1.94	2.9	2.48	2.2	1.94	2.9	1.3
300	3.18	2.64	2.91	4.35	3.72	3.3	2.91	4.35	1.95
400	4.24	3.52	3.88	5.8	4.96	4.4	3.88	5.8	2.6
500	5.3	4.4	4.85	7.25	6.2	5.5	4.85	7.25	3.25
600	6.36	5.28	5.82	8.7	7.44	6.6	5.82	8.7	3.9
700	7.42	6.16	6.79	10.15	8.68	7.7	6.79	10.15	4.55
800	8.48	7.04	7.76	11.6	9.92	8.8	7.76	11.6	5.2
900	9.54	7.92	8.73	13.05	11.16	9.9	8.73	13.05	5.85
1000	10.6	8.8	9.7	14.5	12.4	11	9.7	14.5	6.5
1500	15.9	13.2	14.55	21.75	18.6	16.5	14.55	21.75	9.75
2000	21.2	17.6	19.4	29	24.8	22	19.4	29	13
2500	26.5	22	24.25	36.25	31	27.5	24.25	36.25	16.25
3000	31.8	26.4	29.1	43.5	37.2	33	29.1	43.5	19.5
3500	37.1	30.8	33.95	50.75	43.4	38.5	33.95	50.75	22.75
4000	42.4	35.2	38.8	58	49.6	44	38.8	58	26
4500	47.7	39.6	43.65	65.25	55.8	49.5	43.65	65.25	29.25
5000	53	44	48.5	72.5	62	55	48.5	72.5	32.5
6000	63.6	52.8	58.2	87	74.4	66	58.2	87	39
7000	74.2	61.6	67.9	101.5	86.8	77	67.9	101.5	45.5
8000	84.8	70.4	77.6	116	99.2	88	77.6	116	52

* Based on AIRAH design ambient conditions, 24°C/50RH% Indoor Conditions

Note that ventilators should be run in conjunction with conventional air conditioning to sustain indoor conditions



Energy Reclaimed by Heat Exchanger **Heating*** (kW) - HRV (Sensible Only Transfer)

Model No.	Sydney	Brisbane	North Queensland	Adelaide	Melbourne	Canberra	Darwin	Perth	Hobart
100	1.53	1.53	1.31	1.85	1.91	2.64	0.44	1.8	2.13
200	3.06	3.06	2.62	3.7	3.82	5.28	0.88	3.6	4.26
300	4.59	4.59	3.93	5.55	5.73	7.92	1.32	5.4	6.39
400	6.12	6.12	5.24	7.4	7.64	10.56	1.76	7.2	8.52
500	7.65	7.65	6.55	9.25	9.55	13.2	2.2	9	10.65
600	9.18	9.18	7.86	11.1	11.46	15.84	2.64	10.8	12.78
700	10.71	10.71	9.17	12.95	13.37	18.48	3.08	12.6	14.91
800	12.24	12.24	10.48	14.8	15.28	21.12	3.52	14.4	17.04
900	13.77	13.77	11.79	16.65	17.19	23.76	3.96	16.2	19.17
1000	15.3	15.3	13.1	18.5	19.1	26.4	4.4	18	21.3
1500	22.95	22.95	19.65	27.75	28.65	39.6	6.6	27	31.95
2000	30.6	30.6	26.2	37	38.2	52.8	8.8	36	42.6
2500	38.25	38.25	32.75	46.25	47.75	66	11	45	53.25
3000	45.9	45.9	39.3	55.5	57.3	79.2	13.2	54	63.9
3500	53.55	53.55	45.85	64.75	66.85	92.4	15.4	63	74.55
4000	61.2	61.2	52.4	74	76.4	105.6	17.6	72	85.2
4500	68.85	68.85	58.95	83.25	85.95	118.8	19.8	81	95.85
5000	76.5	76.5	65.5	92.5	95.5	132	22	90	106.5
6000	91.8	91.8	78.6	111	114.6	158.4	26.4	108	127.8
7000	107.1	107.1	91.7	129.5	133.7	184.8	30.8	126	149.1
8000	122.4	122.4	104.8	148	152.8	211.2	35.2	144	170.4

* Based on AIRAH design ambient conditions, 21°C/50RH% Indoor Conditions

Note that ventilators should be run in conjunction with conventional air conditioning to sustain indoor conditions

ERV / HRV550-RT		
TECHNICAL SPECIFICATIONS	UNIT	VALUE
Supply Air	L/s	250-550
Exhaust Air	L/s	250-550
Compressor Qty		NA
Compressor Capacity	kWr	NA
FRESH AIR TO SUPPLY AIR		
Pressure Drop Heat Exchanger	Pa	160
External Static Pressure Up to	Pa	150
Total Pressure on Supply Fan	Pa	310
SUPPLY FAN		
Fan Speed (max)	rpm	1315
Motor Power	kW	0.425
Motor Poles		4
Motor Torque	Nm	N/A
RETURN AIR TO EXHAUST AIR		
Return Air	L/s	250-550
Total Exhaust Air	L/s	250-550
Pressure Drop Heat Exchanger	Pa	160
External Static Pressure Up to	Pa	150
Total Pressure on Exhaust Fan	Pa	310
EXHAUST FAN		
Fan Speed (max)	rpm	1315
Motor Power	kW	0.425
Motor Poles		4
Motor Torque	Nm	N/A
MAKE UP AIR BYPASS		
Fan Qty		0.0
Air Flow	L/s	0.0
Fan Speed		N/A
WATER COIL (OPTIONAL)		
Fin Length	mm	770
Fin Height	mm	444
Face Velocity	m/s	1.61
ELECTRICAL POWERING		
		240/1/50
Current (MCC) (Comp)	A	0.0
Current (LRA) (Comp)	A	0.0
Current (RLA) (Comp)	A	0.0
Supply Fan FLA	A	3.95
Supply Fan LRA	A	0
Exhaust Fan FLA	A	3.95
Exhaust Fan LRA	A	0
Nominal Running Current	A	7.9

ERV/HRV SCHEMATIC:

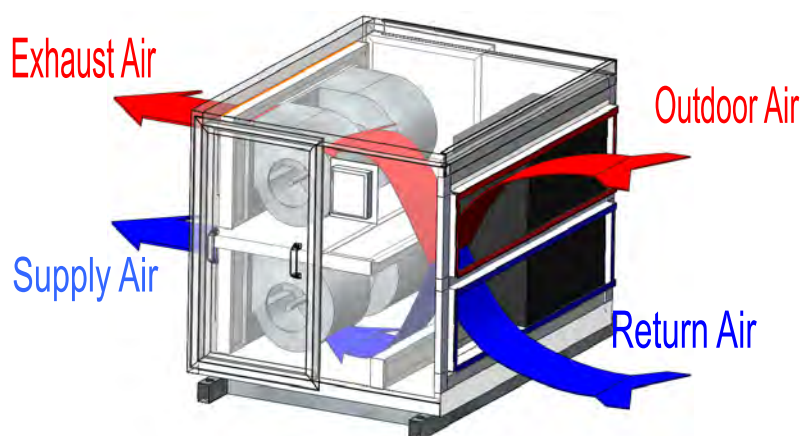

BASE DIMENSIONS:

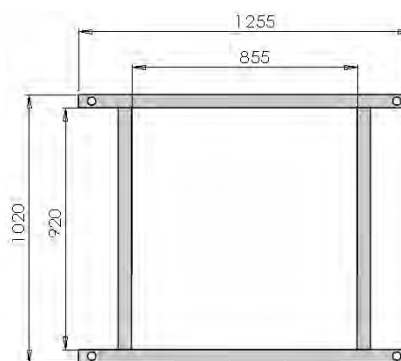

Overall Dimensions

Height: 1040 mm (Body 965)
 Width: 1255 mm (Body 1050)
 Depth: 1230 mm (Body 1155)

Weight

163 kg

Spigot Size

Supply Air (300 X 695)
 Return Air (330 X 955)
 Exhaust Air (300 X 695)
 Outdoor Air (330 X 995)

General

550L/s Energy/Heat Recovery Ventilator

Please Allow 1 m clearance from Unit doors to allow for servicing and maintenance.

Sound Pressure Levels dB(A)

Exhaust @ 1m

63	Hz	57
125	Hz	61
250	Hz	64
500	Hz	74
1000	Hz	71
2000	Hz	72
4000	Hz	71
8000	Hz	61
OA		76

Intake @ 4m

63	Hz	44
125	Hz	50
250	Hz	52
500	Hz	66
1000	Hz	55
2000	Hz	53
4000	Hz	49
8000	Hz	37
IA		67

ERV / HRV750-RT		
TECHNICAL SPECIFICATIONS	UNIT	VALUE
Supply Air	L/s	550-750
Exhaust Air	L/s	550-750
Compressor Qty		NA
Compressor Capacity	kWr	NA
FRESH AIR TO SUPPLY AIR		
Pressure Drop Heat Exchanger	Pa	160
External Static Pressure Up to	Pa	150
Total Pressure on Supply Fan	Pa	310
SUPPLY FAN		
Fan Speed (max)	rpm	1330
Motor Power	kW	0.6
Motor Poles		4
Motor Torque	Nm	N/A
RETURN AIR TO EXHAUST AIR		
Return Air	L/s	550-750
Total Exhaust Air	L/s	550-750
Pressure Drop Heat Exchanger	Pa	160
External Static Pressure Up to	Pa	150
Total Pressure on Exhaust Fan	Pa	310
EXHAUST FAN		
Fan Speed (max)	rpm	1330
Motor Power	kW	0.6
Motor Poles		4
Motor Torque	Nm	N/A
MAKE UP AIR BYPASS		
Fan Qty		0.0
Air Flow	L/s	0.0
Fan Speed		N/A
WATER COIL (OPTIONAL)		
Fin Length	mm	770
Fin Height	mm	444
Face Velocity	m/s	2.19
ELECTRICAL POWERING		240/1/50
Current (MCC) (Comp)	A	0.0
Current (LRA) (Comp)	A	0.0
Current (RLA) (Comp)	A	0.0
Supply Fan FLA	A	4.0
Supply Fan LRA	A	0
Exhaust Fan FLA	A	4.0
Exhaust Fan LRA	A	0
Nominal Running Current	A	8.0

ERV/HRV SCHEMATIC:

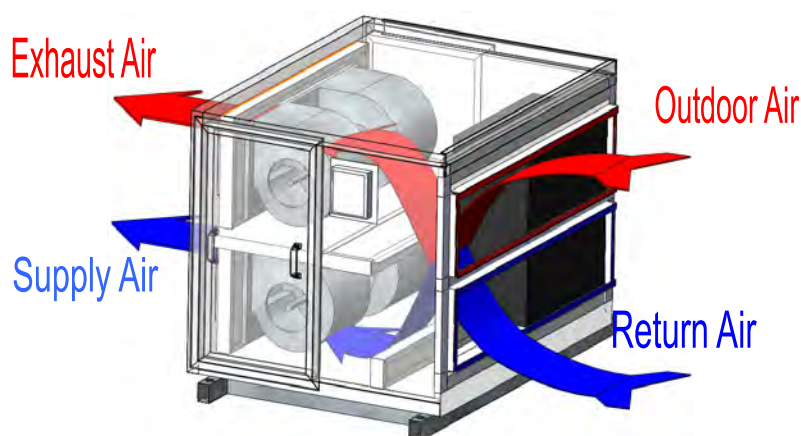

BASE DIMENSIONS:

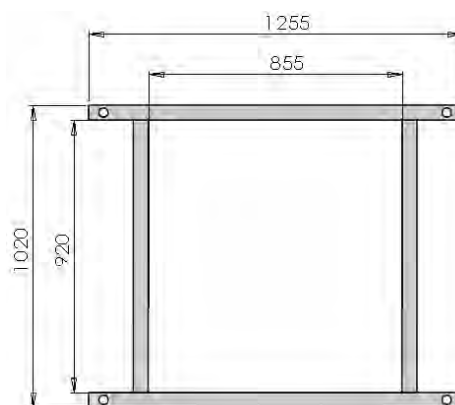

Overall Dimensions

Height: 1040 mm (Body 965)
 Width: 1255 mm (Body 1055)
 Depth: 1230 mm (Body 1150)

Weight

183 kg

Spigot Size

Supply Air (300 X 695)
 Return Air (330 X 955)
 Exhaust Air (300 X 695)
 Outdoor Air (330 X 995)

General

750L/s Energy/Heat Recovery Ventilator

Please Allow 1 m clearance from Unit doors to allow for servicing and maintenance.

Sound Pressure Levels dB(A)

Exhaust @ 1m

63	Hz	57
125	Hz	61
250	Hz	64
500	Hz	74
1000	Hz	71
2000	Hz	72
4000	Hz	71
8000	Hz	61
OA		76

Intake @ 4m

63	Hz	44
125	Hz	50
250	Hz	52
500	Hz	66
1000	Hz	55
2000	Hz	53
4000	Hz	49
8000	Hz	37
IA		67



ERV / HRV1000-RT		
TECHNICAL SPECIFICATIONS	UNIT	VALUE
Supply Air	L/s	750-1000
Exhaust Air	L/s	750-1000
Compressor Qty		NA
Compressor Capacity	kWr	NA
FRESH AIR TO SUPPLY AIR		
Pressure Drop Heat Exchanger	Pa	160
External Static Pressure Up to	Pa	150
Total Pressure on Supply Fan	Pa	310
SUPPLY FAN		
Fan Speed (max)	rpm	1360
Motor Power	kW	0.75
Motor Poles		4
Motor Torque	Nm	N/A
RETURN AIR TO EXHAUST AIR		
Return Air	L/s	750-1000
Total Exhaust Air	L/s	750-1000
Pressure Drop Heat Exchanger	Pa	160
External Static Pressure Up to	Pa	150
Total Pressure on Exhaust Fan	Pa	310
EXHAUST FAN		
Fan Speed (max)	rpm	1360
Motor Power	kW	0.75
Motor Poles		4
Motor Torque	Nm	N/A
MAKE UP AIR BYPASS		
Fan Qty		0.0
Air Flow	L/s	0.0
Fan Speed		N/A
WATER COIL (OPTIONAL)		
Fin Length	mm	800
Fin Height	mm	571
Face Velocity	m/s	2.19
ELECTRICAL POWERING		
		240/1/50
Current (MCC) (Comp)	A	0.0
Current (LRA) (Comp)	A	0.0
Current (RLA) (Comp)	A	0.0
Supply Fan FLA	A	5.3
Supply Fan LRA	A	0
Exhaust Fan FLA	A	5.3
Exhaust Fan LRA	A	0
Nominal Running Current	A	10.6

ERV/HRV SCHEMATIC:

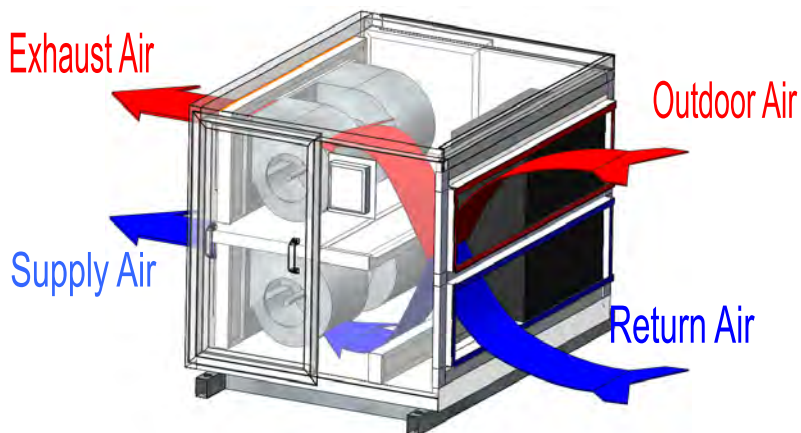

BASE DIMENSIONS:

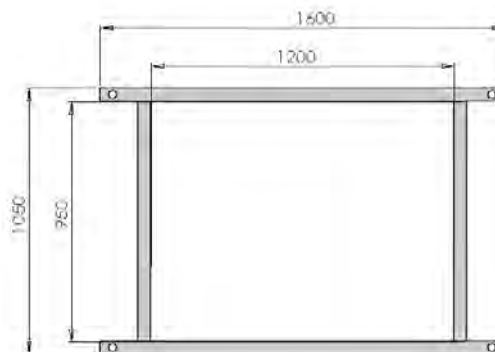

Overall Dimensions

Height: 1155mm (Body 1080)
 Width: 1600 mm (Body 1400)
 Depth: 1260 mm (Body 1180)

Weight

222 kg

Spigot Size

Supply Air (300 x950)
 Return Air (330 X 1300)
 Exhaust Air (300 X 950)
 Outdoor Air (330 X 1300)

General

1000L/s Energy/Heat Recovery Ventilator

Please Allow 1 m clearance from Unit doors to allow for servicing and maintenance.

Sound Pressure Levels dB(A)

Exhaust @ 1m

63	Hz	57
125	Hz	61
250	Hz	64
500	Hz	74
1000	Hz	71
2000	Hz	72
4000	Hz	71
8000	Hz	61
OA		76

Intake @ 4m

63	Hz	44
125	Hz	50
250	Hz	52
500	Hz	66
1000	Hz	55
2000	Hz	53
4000	Hz	49
8000	Hz	37
IA		67



ERV / HRV1500-RT		
TECHNICAL SPECIFICATIONS	UNIT	VALUE
Supply Air	L/s	1000-1500
Exhaust Air	L/s	1000-1500
Compressor Qty		NA
Compressor Capacity	kWr	NA
FRESH AIR TO SUPPLY AIR		
Pressure Drop Heat Exchanger	Pa	167
External Static Pressure Up to	Pa	200
Total Pressure on Supply Fan	Pa	367
SUPPLY FAN		
Fan Speed (max)	rpm	1300
Motor Power	kW	1.2
Motor Poles		4
Motor Torque	Nm	N/A
RETURN AIR TO EXHAUST AIR		
Return Air	L/s	1000-1500
Total Exhaust Air	L/s	1000-1500
Pressure Drop Heat Exchanger	Pa	167
External Static Pressure Up to	Pa	200
Total Pressure on Exhaust Fan	Pa	367
EXHAUST FAN		
Fan Speed (max)	rpm	1300
Motor Power	kW	1.2
Motor Poles		4
Motor Torque	Nm	N/A
MAKE UP AIR BYPASS		
Fan Qty		0.0
Air Flow	L/s	0.0
Fan Speed		N/A
WATER COIL (OPTIONAL)		
Fin Length	mm	1700
Fin Height	mm	762
Face Velocity	m/s	1.16
ELECTRICAL POWERING		
		240/1/50
Current (MCC) (Comp)	A	0.0
Current (LRA) (Comp)	A	0.0
Current (RLA) (Comp)	A	0.0
Supply Fan FLA	A	8.8
Supply Fan LRA	A	0.0
Exhaust Fan FLA	A	8.8
Exhaust Fan LRA	A	0.0
Nominal Running Current	A	17.6

ERV/HRV SCHEMATIC:

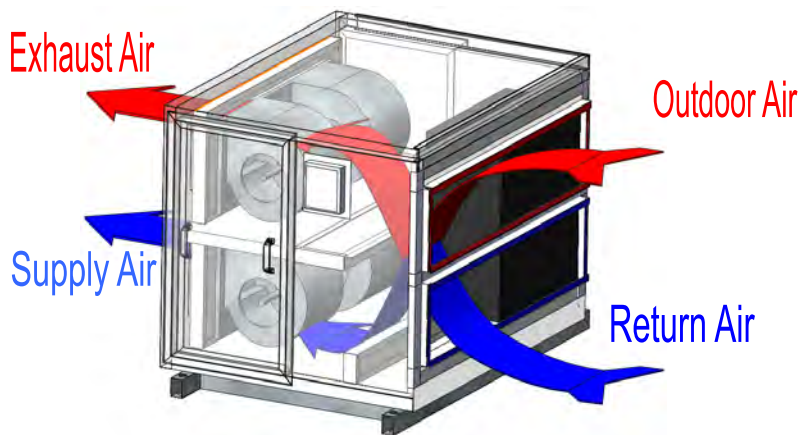

BASE DIMENSIONS:

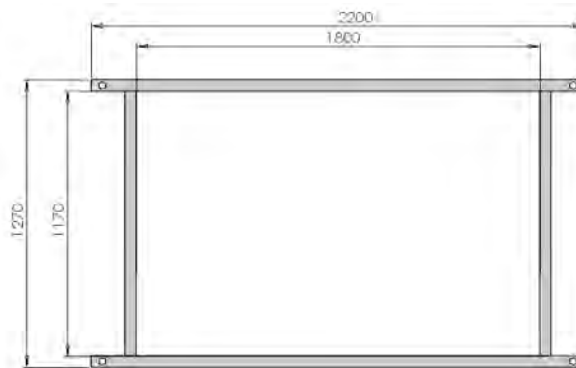

Overall Dimensions

Height: 1295 mm (Body 1220)
 Width: 2200 mm (Body 2000)
 Depth: 1480 mm (Body 1400)

Weight

332 kg

Spigot Size

Supply Air (300 X 1050)
 Return Air (1900 X 330)
 Exhaust Air (300 X 1050)
 Outdoor Air (1900 X 330)

General

1500L/s Energy/Heat Recovery Ventilator

Please Allow 1 m clearance from Unit doors to allow for servicing and maintenance.

Sound Pressure Levels dB(A)

Exhaust @ 1m

63	Hz	52
125	Hz	60
250	Hz	62
500	Hz	74
1000	Hz	71
2000	Hz	72
4000	Hz	70
8000	Hz	60
OA		76

Intake @ 4m

63	Hz	44
125	Hz	50
250	Hz	52
500	Hz	66
1000	Hz	55
2000	Hz	53
4000	Hz	49
8000	Hz	37
IA		67



ERV / HRV2000-RT		
TECHNICAL SPECIFICATIONS	UNIT	VALUE
Supply Air	L/s	1500-2000
Exhaust Air	L/s	1500-2000
Compressor Qty		NA
Compressor Capacity	kWr	NA
FRESH AIR TO SUPPLY AIR		
Pressure Drop Heat Exchanger	Pa	126
External Static Pressure Up to	Pa	250
Total Pressure on Supply Fan	Pa	376
SUPPLY FAN		
Fan Speed (max)	rpm	1360
Motor Power	kW	1.5
Motor Poles		4
Motor Torque	Nm	N/A
RETURN AIR TO EXHAUST AIR		
Return Air	L/s	1500-2000
Total Exhaust Air	L/s	1500-2000
Pressure Drop Heat Exchanger	Pa	126
External Static Pressure Up to	Pa	250
Total Pressure on Exhaust Fan	Pa	376
EXHAUST FAN		
Fan Speed (max)	rpm	1360
Motor Power	kW	1.5
Motor Poles		4
Motor Torque	Nm	N/A
MAKE UP AIR BYPASS		
Fan Qty		0.0
Air Flow	L/s	0.0
Fan Speed		N/A
WATER COIL (OPTIONAL)		
Fin Length	mm	1700
Fin Height	mm	571
Face Velocity	m/s	2.06
ELECTRICAL POWERING		240/1/50
Current (MCC) (Comp)	A	0.0
Current (LRA) (Comp)	A	0.0
Current (RLA) (Comp)	A	0.0
Supply Fan FLA	A	9.8
Supply Fan LRA	A	0.0
Exhaust Fan FLA	A	9.8
Exhaust Fan LRA	A	0.0
Nominal Running Current	A	19.6

ERV/HRV SCHEMATIC:

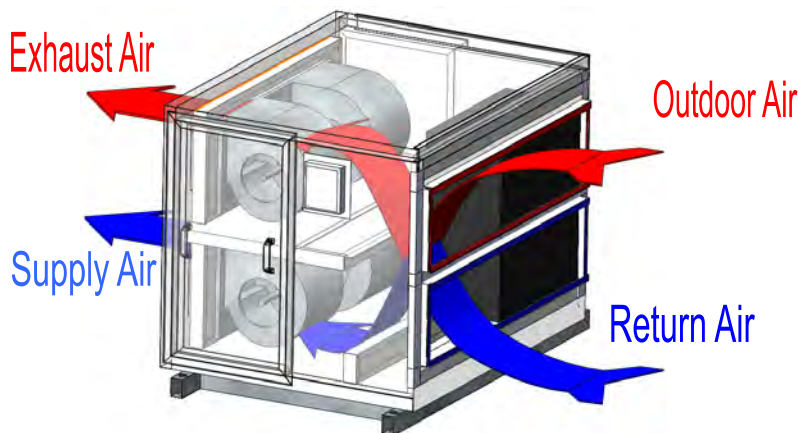

BASE DIMENSIONS:

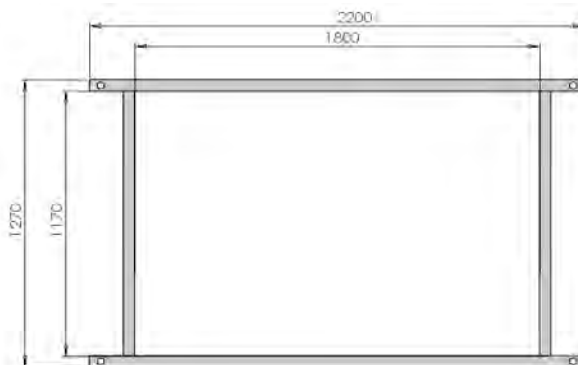

Overall Dimensions

Height: 1295 mm (Body 1220)
 Width: 2200 mm (Body 2000)
 Depth: 1480 mm (Body 1400)

Weight

353 kg

Spigot Size

Supply Air (300 X 1050)
 Return Air (1900 X 330)
 Exhaust Air (300 X 1050)
 Outdoor Air (1900 X 330)

General

2000L/s Energy/Heat Recovery Ventilator

Please Allow 1 m clearance from Unit doors to allow for servicing and maintenance.

Sound Pressure Levels dB(A)

Exhaust @ 1m

63	Hz	52
125	Hz	60
250	Hz	62
500	Hz	74
1000	Hz	71
2000	Hz	72
4000	Hz	70
8000	Hz	60
OA		76

Intake @ 4m

63	Hz	44
125	Hz	50
250	Hz	52
500	Hz	66
1000	Hz	55
2000	Hz	53
4000	Hz	49
8000	Hz	37
IA		67



ERV / HRV2500-RT		
TECHNICAL SPECIFICATIONS	UNIT	VALUE
Supply Air	L/s	2000-2500
Exhaust Air	L/s	2000-2500
Compressor Qty		NA
Compressor Capacity	kWr	NA
FRESH AIR TO SUPPLY AIR		
Pressure Drop Heat Exchanger	Pa	174
External Static Pressure Up to	Pa	300
Total Pressure on Supply Fan	Pa	474
SUPPLY FAN		
Fan Speed (max)	rpm	1800
Motor Power	kW	4
Motor Poles		4
Motor Torque	Nm	26.6
RETURN AIR TO EXHAUST AIR		
Return Air	L/s	2000-2500
Total Exhaust Air	L/s	2000-2500
Pressure Drop Heat Exchanger	Pa	174
External Static Pressure Up to	Pa	300
Total Pressure on Exhaust Fan	Pa	474
EXHAUST FAN		
Fan Speed (max)	rpm	1800
Motor Power	kW	4
Motor Poles		4
Motor Torque	Nm	26.6
MAKE UP AIR BYPASS		
Fan Qty		0.0
Air Flow	L/s	0.0
Fan Speed		N/A
WATER COIL (OPTIONAL)		
Fin Length	mm	1790
Fin Height	mm	762
Face Velocity	m/s	1.83
ELECTRICAL POWERING		
		415/3/50
Current (MCC) (Comp)	A	0.0
Current (LRA) (Comp)	A	0.0
Current (RLA) (Comp)	A	0.0
Supply Fan FLA	A	8.0
Supply Fan LRA	A	56.1
Exhaust Fan FLA	A	8.0
Exhaust Fan LRA	A	56.1
Nominal Running Current	A	16/16/16

ERV/HRV SCHEMATIC:

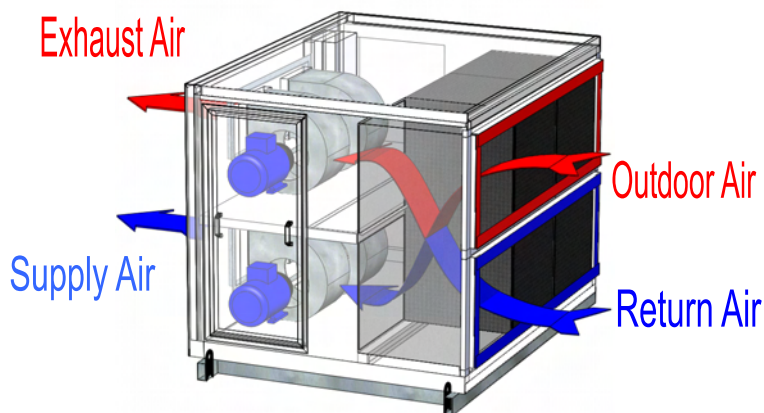

BASE DIMENSIONS:

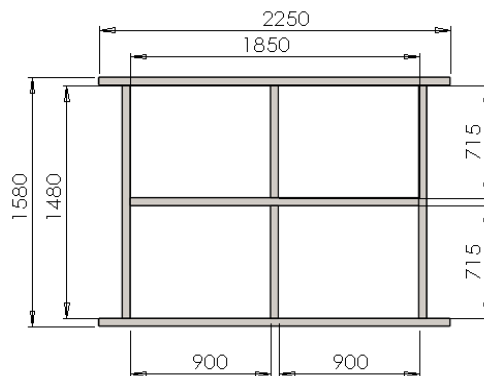

Overall Dimensions

Height: 1770 mm (Body 1670)
 Width: 2250 mm (Body 2050)
 Depth: 1770 mm (Body 1710)

Weight

736 kg

Spigot Size

Supply Air (380 X 870)
 Return Air (620 X 1950)
 Exhaust Air (380 X 870)
 Outdoor Air (620 X 1950)

General

2500L/s Energy/Heat Recovery Ventilator

Please Allow 1.2 m clearance from Unit doors to allow for servicing and maintenance.

Sound Pressure Levels dB(A)

Exhaust @ 1m

63	Hz	52
125	Hz	60
250	Hz	62
500	Hz	74
1000	Hz	71
2000	Hz	72
4000	Hz	70
8000	Hz	60
OA		76

Intake @ 4m

63	Hz	44
125	Hz	50
250	Hz	52
500	Hz	66
1000	Hz	55
2000	Hz	53
4000	Hz	49
8000	Hz	37
IA		67



ERV / HRV3000-RT		
TECHNICAL SPECIFICATIONS	UNIT	VALUE
Supply Air	L/s	3000
Exhaust Air	L/s	3000
Compressor Qty		NA
Compressor Capacity	kWr	NA
FRESH AIR TO SUPPLY AIR		
Pressure Drop Heat Exchanger	Pa	221
External Static Pressure Up to	Pa	300
Total Pressure on Supply Fan	Pa	521
SUPPLY FAN		
Fan Speed (max)	rpm	1800
Motor Power	kW	5.5
Motor Poles		4
Motor Torque	Nm	36.4
RETURN AIR TO EXHAUST AIR		
Return Air	L/s	3000
Total Exhaust Air	L/s	3000
Pressure Drop Heat Exchanger	Pa	221
External Static Pressure Up to	Pa	300
Total Pressure on Exhaust Fan	Pa	521
EXHAUST FAN		
Fan Speed (max)	rpm	1800
Motor Power	kW	5.5
Motor Poles		4
Motor Torque	Nm	36.4
MAKE UP AIR BYPASS		
Fan Qty		0.0
Air Flow	L/s	0.0
Fan Speed		N/A
WATER COIL (OPTIONAL)		
Fin Length	mm	1790
Fin Height	mm	762
Face Velocity	m/s	2.2
ELECTRICAL POWERING		
		415/3/50
Current (MCC) (Comp)	A	0.0
Current (LRA) (Comp)	A	0.0
Current (RLA) (Comp)	A	0.0
Supply Fan FLA	A	10.8
Supply Fan LRA	A	75.6
Exhaust Fan FLA	A	10.8
Exhaust Fan LRA	A	75.6
Nominal Running Current	A	21.6/21.6/21.6

ERV/HRV SCHEMATIC:

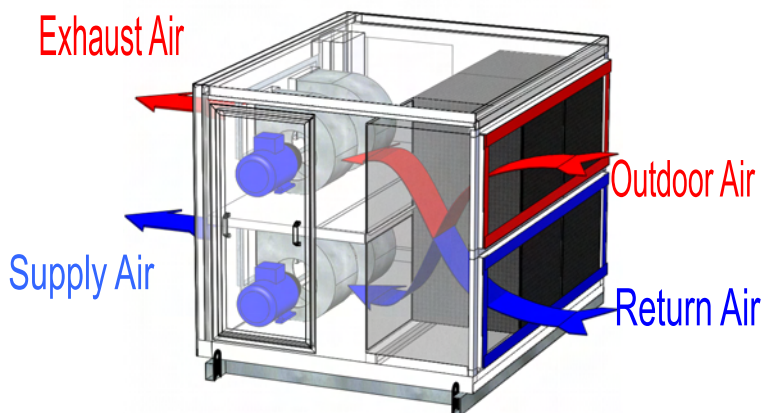

BASE DIMENSIONS:

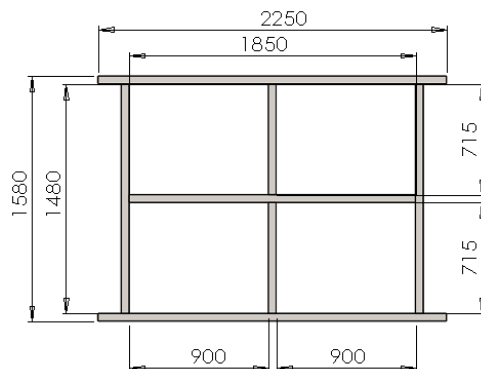

Overall Dimensions

Height: 1770 mm (Body 1670)
 Width: 2250 mm (Body 2050)
 Depth: 1825 mm (Body 1710)

Weight

768kg

Spigot Size

Supply Air (380 X 870)
 Return Air (1950 X 620)
 Exhaust Air (380 x 870)
 Outdoor Air (1950 x 870)

General

3000L/s Energy/Heat Recovery Ventilator

Please Allow 1.2 m clearance from Unit doors to allow for servicing and maintenance.

Sound Pressure Levels dB(A)

Exhaust @ 1m

63	Hz	56
125	Hz	61
250	Hz	64
500	Hz	73
1000	Hz	70
2000	Hz	72
4000	Hz	70
8000	Hz	61
OA	Hz	79

Intake @ 4m

63	Hz	44
125	Hz	50
250	Hz	52
500	Hz	66
1000	Hz	55
2000	Hz	53
4000	Hz	49
8000	Hz	37
IA	Hz	67

ERV / HRV3500-RT		
TECHNICAL SPECIFICATIONS	UNIT	VALUE
Supply Air	L/s	3500
Exhaust Air	L/s	3500
Compressor Qty		NA
Compressor Capacity	kWr	NA
FRESH AIR TO SUPPLY AIR		
Pressure Drop Heat Exchanger	Pa	185
External Static Pressure Up to	Pa	350
Total Pressure on Supply Fan	Pa	535
SUPPLY FAN		
Fan Speed (max)	rpm	1400
Motor Power	kW	5.5
Motor Poles		4
Motor Torque	Nm	36.4
RETURN AIR TO EXHAUST AIR		
Return Air	L/s	3500
Total Exhaust Air	L/s	3500
Pressure Drop Heat Exchanger	Pa	185
External Static Pressure Up to	Pa	350
Total Pressure on Exhaust Fan	Pa	535
EXHAUST FAN		
Fan Speed (max)	rpm	1400
Motor Power	kW	5.5
Motor Poles		4
Motor Torque	Nm	36.4
MAKE UP AIR BYPASS		
Fan Qty		0.0
Air Flow	L/s	0.0
Fan Speed		N/A
WATER COIL (OPTIONAL)		
Fin Length	mm	2400
Fin Height	mm	762
Face Velocity	m/s	1.91
ELECTRICAL POWERING		
		415/3/50
Current (MCC) (Comp)	A	0.0
Current (LRA) (Comp)	A	0.0
Current (RLA) (Comp)	A	0.0
Supply Fan FLA	A	10.8
Supply Fan LRA	A	75.6
Exhaust Fan FLA	A	10.8
Exhaust Fan LRA	A	75.6
Nominal Running Current	A	21.6/21.6/21.6

ERV/HRV SCHEMATIC:

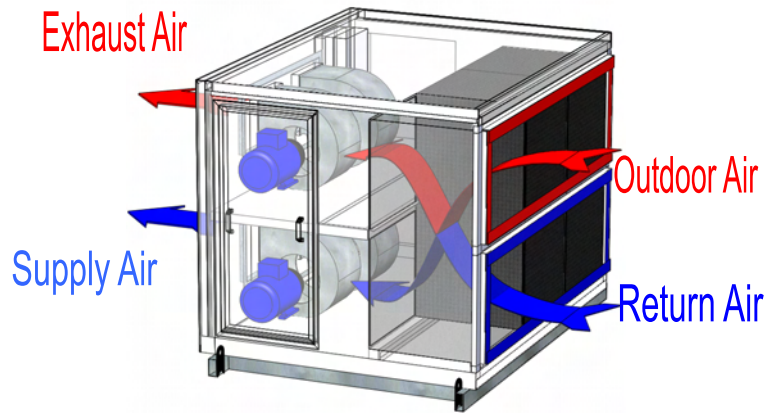

BASE DIMENSIONS:

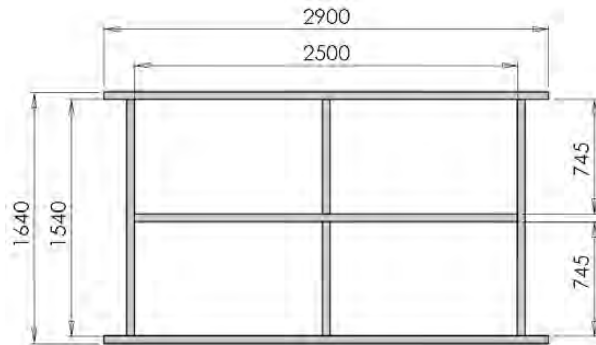

Overall Dimensions

Height: 1770 mm (Body 1670)
Width: 2900 mm (Body 2700)
Depth: 1885 mm (Body 1770)

Weight

963kg

Spigot Size

Supply Air (425 X 1050)
Return Air (2600 X 620)
Exhaust Air (425 X 1050)
Outdoor Air (2600 X 620)

General

3500L/s Energy/Heat Recovery Ventilator

Please Allow 1.5 m clearance from Unit doors to allow for servicing and maintenance.

Sound Pressure Levels dB(A)

Exhaust @ 1m

63	Hz	56
125	Hz	61
250	Hz	64
500	Hz	73
1000	Hz	70
2000	Hz	72
4000	Hz	70
8000	Hz	61
OA	Hz	79

Intake @ 4m

63	Hz	44
125	Hz	50
250	Hz	52
500	Hz	66
1000	Hz	55
2000	Hz	53
4000	Hz	49
8000	Hz	37
IA	Hz	67



ERV / HRV4000-RT		
TECHNICAL SPECIFICATIONS	UNIT	VALUE
Supply Air	L/s	4000
Exhaust Air	L/s	4000
Compressor Qty		NA
Compressor Capacity	kWr	NA
FRESH AIR TO SUPPLY AIR		
Pressure Drop Heat Exchanger	Pa	221
External Static Pressure Up to	Pa	350
Total Pressure on Supply Fan	Pa	571
SUPPLY FAN		
Fan Speed (max)	rpm	1400
Motor Power	kW	7.5
Motor Poles		4
Motor Torque	Nm	49.6
RETURN AIR TO EXHAUST AIR		
Return Air	L/s	4000
Total Exhaust Air	L/s	4000
Pressure Drop Heat Exchanger	Pa	221
External Static Pressure Up to	Pa	350
Total Pressure on Exhaust Fan	Pa	571
EXHAUST FAN		
Fan Speed (max)	rpm	1400
Motor Power	kW	7.5
Motor Poles		4
Motor Torque	Nm	49.6
MAKE UP AIR BYPASS		
Fan Qty		0.0
Air Flow	L/s	0.0
Fan Speed		N/A
WATER COIL (OPTIONAL)		
Fin Length	mm	2400
Fin Height	mm	762
Face Velocity	m/s	2.19
ELECTRICAL POWERING		
		415/3/50
Current (MCC) (Comp)	A	0.0
Current (LRA) (Comp)	A	0.0
Current (RLA) (Comp)	A	0.0
Supply Fan FLA	A	14.3
Supply Fan LRA	A	99.4
Exhaust Fan FLA	A	14.3
Exhaust Fan LRA	A	99.4
Nominal Running Current	A	28.6/28.6/28.6

ERV/HRV SCHEMATIC:

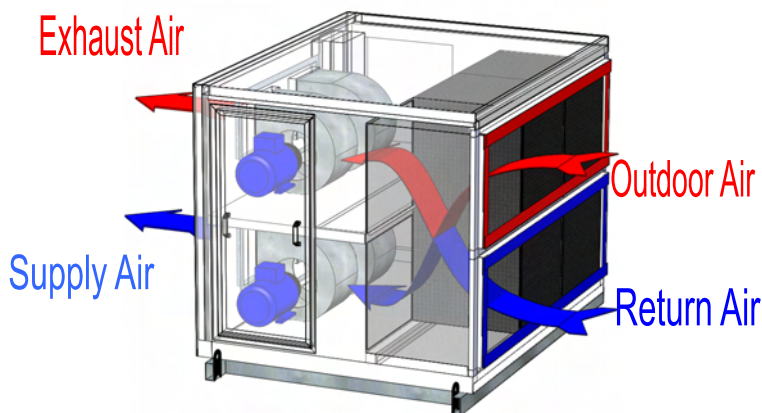

BASE DIMENSIONS:

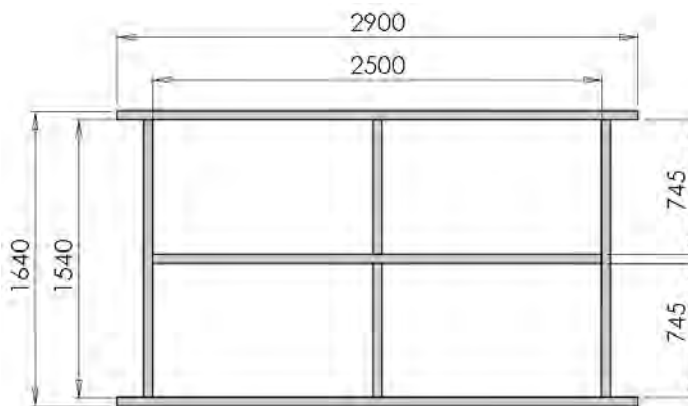

Overall Dimensions

Height: 1770 mm (Body 1670)
 Width: 2900 mm (Body 2700)
 Depth: 1885 mm (Body 1770)

Weight

978kg

Spigot Size

Supply Air (425 X 1050)
 Return Air (2600 X 620)
 Exhaust Air (425 X 1050)
 Outdoor Air (2600 X 620)

General

4000L/s Energy/Heat Recovery Ventilator

Please Allow 1.5 m clearance from Unit doors to allow for servicing and maintenance.

Sound Pressure Levels dB(A)

Exhaust @ 1m

63	Hz	57
125	Hz	61
250	Hz	64
500	Hz	74
1000	Hz	71
2000	Hz	72
4000	Hz	71
8000	Hz	61
OA	Hz	79

Intake @ 4m

63	Hz	44
125	Hz	50
250	Hz	52
500	Hz	66
1000	Hz	55
2000	Hz	53
4000	Hz	49
8000	Hz	37
IA	Hz	67



ERV / HRV4500-RT		
TECHNICAL SPECIFICATIONS	UNIT	VALUE
Supply Air	L/s	4500
Exhaust Air	L/s	4500
Compressor Qty		NA
Compressor Capacity	kWr	NA
FRESH AIR TO SUPPLY AIR		
Pressure Drop Heat Exchanger	Pa	192
External Static Pressure Up to	Pa	350
Total Pressure on Supply Fan	Pa	542
SUPPLY FAN		
Fan Speed (max)	rpm	1100
Motor Power	kW	7.5
Motor Poles		4
Motor Torque	Nm	49.6
RETURN AIR TO EXHAUST AIR		
Return Air	L/s	4500
Total Exhaust Air	L/s	4500
Pressure Drop Heat Exchanger	Pa	192
External Static Pressure Up to	Pa	350
Total Pressure on Exhaust Fan	Pa	542
EXHAUST FAN		
Fan Speed (max)	rpm	1100
Motor Power	kW	7.5
Motor Poles		4
Motor Torque	Nm	49.6
MAKE UP AIR BYPASS		
Fan Qty		0.0
Air Flow	L/s	0.0
Fan Speed		N/A
WATER COIL (OPTIONAL)		
Fin Length	mm	3050
Fin Height	mm	762
Face Velocity	m/s	1.94
ELECTRICAL POWERING		
		415/3/50
Current (MCC) (Comp)	A	0.0
Current (LRA) (Comp)	A	0.0
Current (RLA) (Comp)	A	0.0
Supply Fan FLA	A	14.3
Supply Fan LRA	A	99.4
Exhaust Fan FLA	A	14.3
Exhaust Fan LRA	A	99.4
Nominal Running Current	A	28.6/28.6/28.6

ERV/HRV SCHEMATIC:

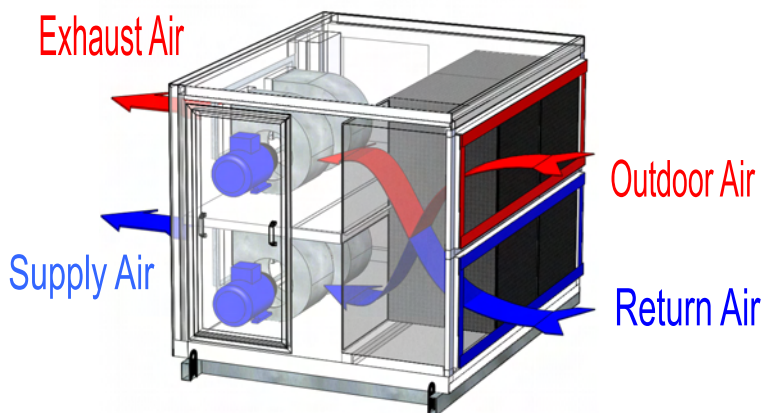

BASE DIMENSIONS:

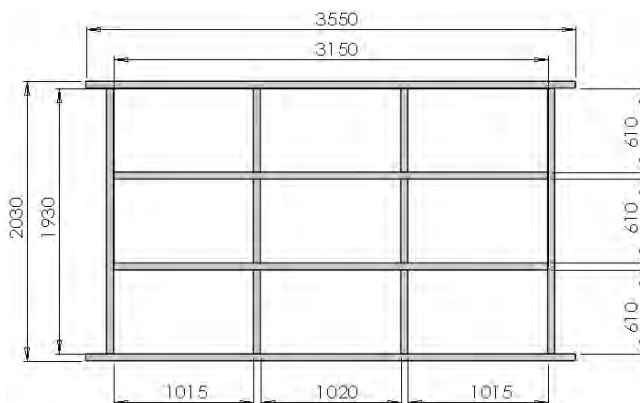

Overall Dimensions

Height: 2040 mm (Body 1940)
 Width: 3550 mm (Body 3350)
 Depth: 2275 mm (Body 2160)

Weight

1289kg

Spigot Size

Supply Air (500 X 1200)
 Return Air (620 X 3250)
 Exhaust Air (500 X 1200)
 Outdoor Air (620 X 3250)

General

4500L/s Energy/Heat Recovery Ventilator

Please Allow 1.5 m clearance from Unit doors to allow for servicing and maintenance.

Sound Pressure Levels dB(A)

Exhaust @ 1m

Frequency (Hz)	Sound Pressure Level (dB(A))
63	51
125	62
250	65
500	72
1000	71
2000	73
4000	72
8000	62
OA	78

Intake @ 4m

Frequency (Hz)	Sound Pressure Level (dB(A))
63	47
125	49
250	52
500	59
1000	55
2000	54
4000	49
8000	39
IA	63



ERV / HRV5000-RT		
TECHNICAL SPECIFICATIONS	UNIT	VALUE
Supply Air	L/s	5000
Exhaust Air	L/s	5000
Compressor Qty		NA
Compressor Capacity	kWr	NA
FRESH AIR TO SUPPLY AIR		
Pressure Drop Heat Exchanger	Pa	221
External Static Pressure Up to	Pa	350
Total Pressure on Supply Fan	Pa	571
SUPPLY FAN		
Fan Speed (max)	rpm	1100
Motor Power	kW	7.5
Motor Poles		6
Motor Torque	Nm	74
RETURN AIR TO EXHAUST AIR		
Return Air	L/s	5000
Total Exhaust Air	L/s	5000
Pressure Drop Heat Exchanger	Pa	221
External Static Pressure Up to	Pa	350
Total Pressure on Exhaust Fan	Pa	571
EXHAUST FAN		
Fan Speed (max)	rpm	1100
Motor Power	kW	7.5
Motor Poles		6
Motor Torque	Nm	74
MAKE UP AIR BYPASS		
Fan Qty		0.0
Air Flow	L/s	0.0
Fan Speed		N/A
WATER COIL (OPTIONAL)		
Fin Length	mm	3050
Fin Height	mm	762
Face Velocity	m/s	2.15
ELECTRICAL POWERING		415/3/50
Current (MCC) (Comp)	A	0.0
Current (LRA) (Comp)	A	0.0
Current (RLA) (Comp)	A	0.0
Supply Fan FLA	A	15.6
Supply Fan LRA	A	101.4
Exhaust Fan FLA	A	15.6
Exhaust Fan LRA	A	101.4
Nominal Running Current	A	31.2

ERV/HRV SCHEMATIC:

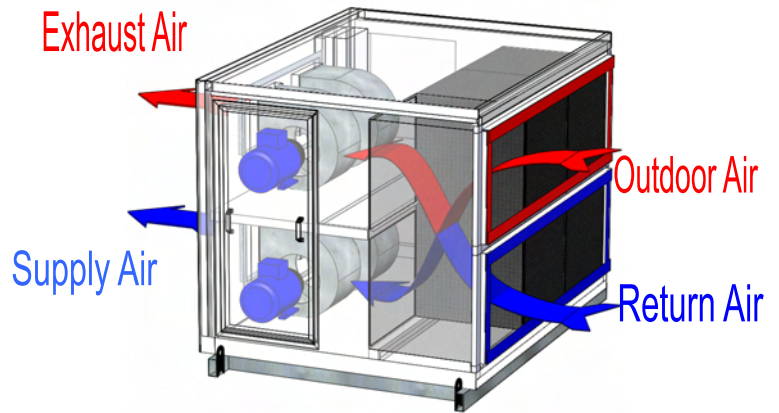

BASE DIMENSIONS:

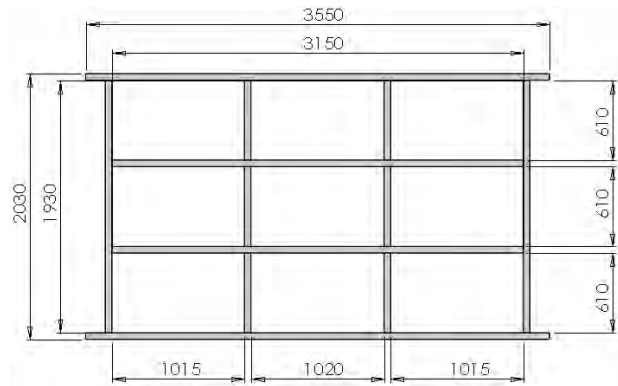

Overall Dimensions

Height: 2040 mm (Body 1940)
 Width: 3550 mm (Body 3350)
 Depth: 2275 mm (Body 2160)

Weight

1358kg

Spigot Size

Supply Air (500 X 1200)
 Return Air (620 X 3250)
 Exhaust Air (500 X 1200)
 Outdoor Air (620 X 3250)

General

5000L/s Energy/Heat Recovery Ventilator

Please Allow 1.5 m clearance from Unit doors to allow for servicing and maintenance.

Sound Pressure Levels dB(A)

Exhaust @ 1m

Frequency (Hz)	Sound Pressure Level (dB(A))
63	51
125	62
250	65
500	72
1000	71
2000	73
4000	72
8000	62
OA	78

Intake @ 4m

Frequency (Hz)	Sound Pressure Level (dB(A))
63	47
125	49
250	52
500	59
1000	55
2000	54
4000	49
8000	39
IA	63



ERV / HRV6000-RT		
TECHNICAL SPECIFICATIONS	UNIT	VALUE
Supply Air	L/s	6000
Exhaust Air	L/s	6000
Compressor Qty		NA
Compressor Capacity	kWr	NA
FRESH AIR TO SUPPLY AIR		
Pressure Drop Heat Exchanger	Pa	221
External Static Pressure Up to	Pa	350
Total Pressure on Supply Fan	Pa	571
SUPPLY FAN		
Fan Speed (max)	rpm	1100
Motor Power	kW	11
Motor Poles		4
Motor Torque	Nm	72
RETURN AIR TO EXHAUST AIR		
Return Air	L/s	6000
Total Exhaust Air	L/s	6000
Pressure Drop Heat Exchanger	Pa	221
External Static Pressure Up to	Pa	350
Total Pressure on Exhaust Fan	Pa	571
EXHAUST FAN		
Fan Speed (max)	rpm	1200
Motor Power	kW	11
Motor Poles		4
Motor Torque	Nm	49.2
MAKE UP AIR BYPASS		
Fan Qty		0.0
Air Flow	L/s	0.0
Fan Speed		N/A
WATER COIL (OPTIONAL)		
Fin Length	mm	3700
Fin Height	mm	762
Face Velocity	m/s	2.13
ELECTRICAL POWERING		415/3/50
Current (MCC) (Comp)	A	0.0
Current (LRA) (Comp)	A	0.0
Current (RLA) (Comp)	A	0.0
Supply Fan FLA	A	15.6
Supply Fan LRA	A	137.8
Exhaust Fan FLA	A	15.6
Exhaust Fan LRA	A	137.8
Nominal Running Current	A	31.2

ERV/HRV SCHEMATIC:

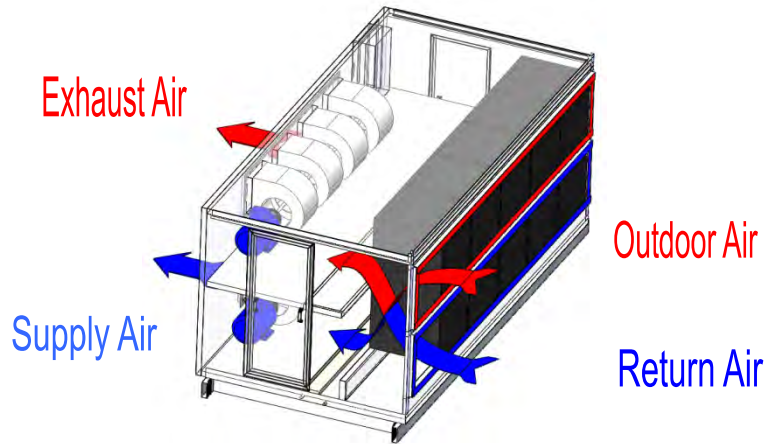

BASE DIMENSIONS:

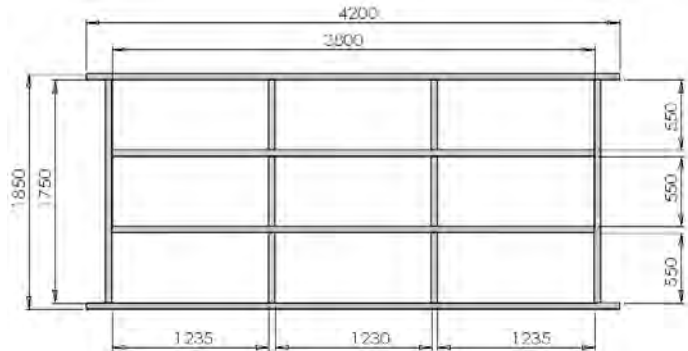

Overall Dimensions

Height: 1820 mm (Body 1670)
 Width: 4200 mm (Body 4000)
 Depth: 2095 mm (Body 1980)

Weight

1560 kg
Spigot Size
 Supply Air (380 X 2000)
 Return Air (3900 X 620)
 Exhaust Air (380 X 2000)
 Outdoor Air (3900 X 620)

General

6000L/s Energy/Heat Recovery Ventilator

Please Allow 1.2 m clearance from Unit doors to allow for servicing and maintenance.

Sound Pressure Levels dB(A)

Exhaust @ 1m

63	Hz	54
125	Hz	65
250	Hz	69
500	Hz	76
1000	Hz	75
2000	Hz	77
4000	Hz	76
8000	Hz	65
OA	Hz	79

Intake @ 4m

63	Hz	49
125	Hz	52
250	Hz	55
500	Hz	62
1000	Hz	58
2000	Hz	57
4000	Hz	52
8000	Hz	41
IA	Hz	65



ERV / HRV7000-RT		
TECHNICAL SPECIFICATIONS	UNIT	VALUE
Supply Air	L/s	7000
Exhaust Air	L/s	7000
Compressor Qty		NA
Compressor Capacity	kWr	NA
FRESH AIR TO SUPPLY AIR		
Pressure Drop Heat Exchanger	Pa	221
External Static Pressure Up to	Pa	350
Total Pressure on Supply Fan	Pa	571
SUPPLY FAN		
Fan Speed (max)	rpm	1000
Motor Power	kW	11.0
Motor Poles		4
Motor Torque	Nm	72
RETURN AIR TO EXHAUST AIR		
Return Air	L/s	7000
Total Exhaust Air	L/s	7000
Pressure Drop Heat Exchanger	Pa	221
External Static Pressure Up to	Pa	350
Total Pressure on Exhaust Fan	Pa	571
EXHAUST FAN		
Fan Speed (max)	rpm	1000
Motor Power	kW	11.0
Motor Poles		4
Motor Torque	Nm	72
MAKE UP AIR BYPASS		
Fan Qty		0.0
Air Flow	L/s	0.0
Fan Speed		N/A
WATER COIL (OPTIONAL)		
Fin Length	mm	4350
Fin Height	mm	762
Face Velocity	m/s	2.11
ELECTRICAL POWERING		415/3/50
Current (MCC) (Comp)	A	0.0
Current (LRA) (Comp)	A	0.0
Current (RLA) (Comp)	A	0.0
Supply Fan FLA	A	21.6
Supply Fan LRA	A	137.8
Exhaust Fan FLA	A	21.6
Exhaust Fan LRA	A	137.8
Nominal Running Current	A	41.4

ERV/HRV SCHEMATIC:

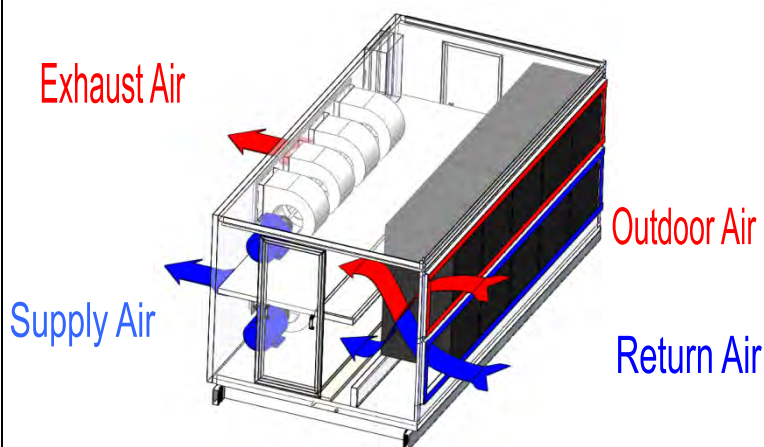

BASE DIMENSIONS:

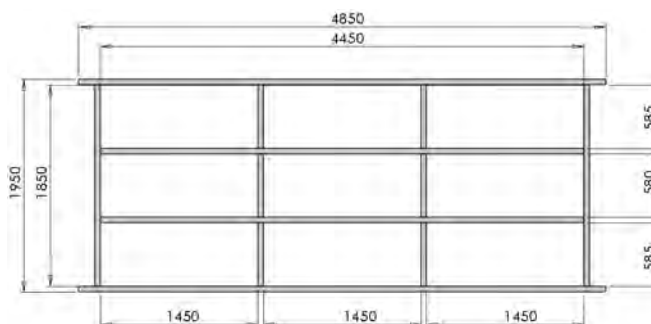

Overall Dimensions

Height: 1820 mm (Body 1670)
 Width: 4850 mm (Body 4650)
 Depth: 2195 mm (Body 2080)

Weight

1744 kg

Spigot Size

Supply Air (500 X 1900)
 Return Air (4550 X 620)
 Exhaust Air (500 X 1900)
 Outdoor Air (4550 X 620)

General

7000L/s Energy/Heat Recovery Ventilator

Please Allow 1.5 m clearance from Unit doors to allow for servicing and maintenance.

Sound Pressure Levels dB(A)

Exhaust @ 1m

63	Hz	54
125	Hz	65
250	Hz	69
500	Hz	76
1000	Hz	75
2000	Hz	77
4000	Hz	76
8000	Hz	65
OA	Hz	79

Intake @ 4m

63	Hz	49
125	Hz	52
250	Hz	55
500	Hz	62
1000	Hz	58
2000	Hz	57
4000	Hz	52
8000	Hz	41
IA	Hz	65



ERV / HRV8000-RT		
TECHNICAL SPECIFICATIONS	UNIT	VALUE
Supply Air	L/s	8000
Exhaust Air	L/s	8000
Compressor Qty		NA
Compressor Capacity	kWr	NA
FRESH AIR TO SUPPLY AIR		
Pressure Drop Heat Exchanger	Pa	222
Pressure Drop Coil	Pa	200
External Static Pressure Up to	Pa	350
Total Pressure on Supply Fan	Pa	772
SUPPLY FAN		
Fan Speed (max)	rpm	1300
Motor Power	kW	15
Motor Poles		4
Motor Torque	Nm	98
RETURN AIR TO EXHAUST AIR		
Return Air	L/s	8000
Total Exhaust Air	L/s	8000
Pressure Drop Heat Exchanger	Pa	222
External Static Pressure Up to	Pa	350
Total Pressure on Exhaust Fan	Pa	572
EXHAUST FAN		
Fan Speed (max)	rpm	1300
Motor Power	kW	15
Motor Poles		4
Motor Torque	Nm	98
MAKE UP AIR BYPASS		
Fan Qty		0.0
Air Flow	L/s	0.0
Fan Speed		N/A
WATER COIL (OPTIONAL)		
Fin Length	mm	5000
Fin Height	mm	762
Face Velocity	m/s	2.10
ELECTRICAL POWERING		415/3/50
Current (MCC) (Comp)	A	0.0
Current (LRA) (Comp)	A	0.0
Current (RLA) (Comp)	A	0.0
Supply Fan FLA	A	28.4
Supply Fan LRA	A	200.9
Exhaust Fan FLA	A	28.4
Exhaust Fan LRA	A	200.9
Nominal Running Current	A	56.8

ERV/HRV SCHEMATIC:

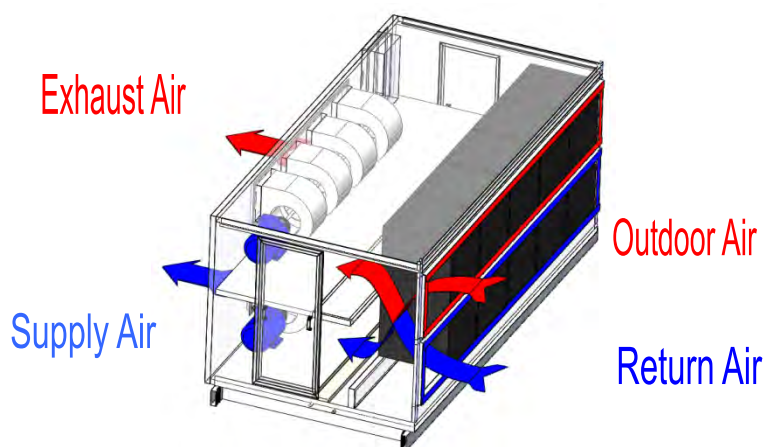

BASE DIMENSIONS:

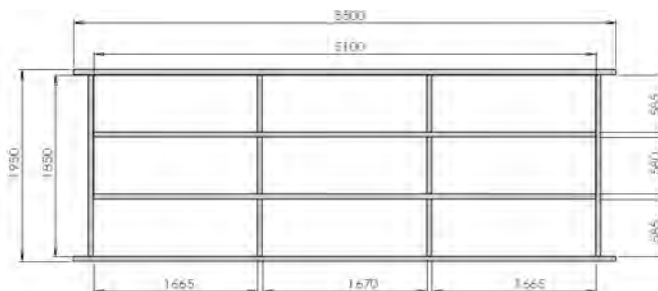

Overall Dimensions

Height: 1820 mm (Body 1670)
 Width: 5500 mm (Body 5300)
 Depth: 2195 mm (Body 2080)

Weight

1946 kg

Spigot Size

Supply Air (425 X 2400)
 Return Air (5200 X 620)
 Exhaust Air (425 X 2400)
 Outdoor Air (5200 X 620)

General

8000L/s Energy/Heat Recovery Ventilator

Please Allow 1.5 m clearance from Unit doors to allow for servicing and maintenance.

Sound Pressure Levels dB(A)

Exhaust @ 1m

63	Hz	51
125	Hz	62
250	Hz	65
500	Hz	72
1000	Hz	71
2000	Hz	73
4000	Hz	72
8000	Hz	62
OA	Hz	78

Intake @ 4m

63	Hz	47
125	Hz	49
250	Hz	52
500	Hz	59
1000	Hz	55
2000	Hz	54
4000	Hz	49
8000	Hz	39
IA	Hz	63